

REMACLEAN SGB

Cleated conveyor belt cleaning brush

REMACLEAN SGB – the cleaning system for cleated conveyor belts – the one and only worldwide

Innovative cleaning

REMACLEAN SGB is the most effective cleaning system for inclined conveyors (cleated conveyor belts) on the market, offering a compelling range of excellent product features. Customized geared electric motors, tuned to belt width, belt speed and height of the cleats, deliver an optimum cleaning result. The specially developed rubber bristles, made of proven **REMALINE**-quality rubber, ensure a particularly long, low-wear service life.



The intense, yet gentle belt cleaning action of **REMACLEAN SGB** therefore guarantees a long service life for your cleated conveyor belt. A permanent reduction in operating costs means our brushes are a worthwhile investment.

Typical areas of application

- Nonmetallic minerals industry
- Lumber and particle board mills
- Calcareous sandstone processing plants
- Composting facilities



One Name – One Source – One System

REMACLEAN SGB

Cleated conveyor belt cleaning brush

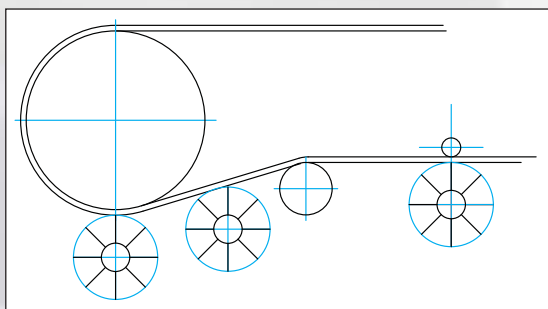
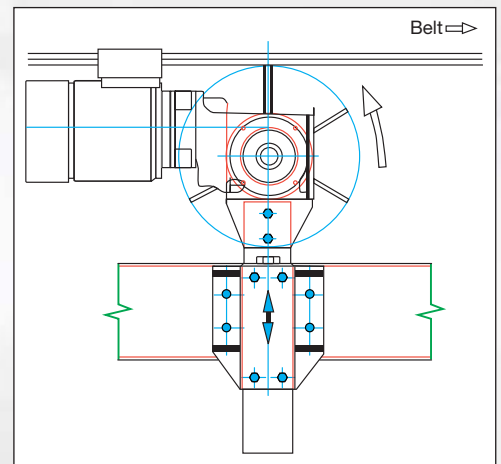
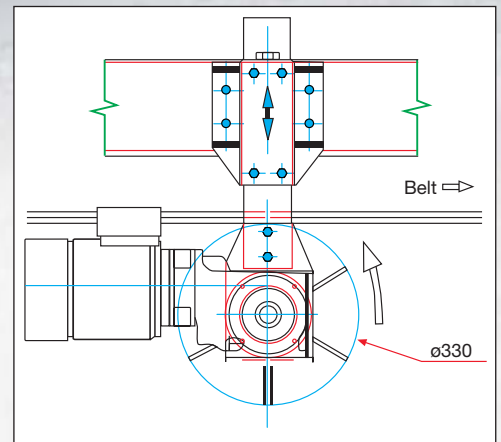
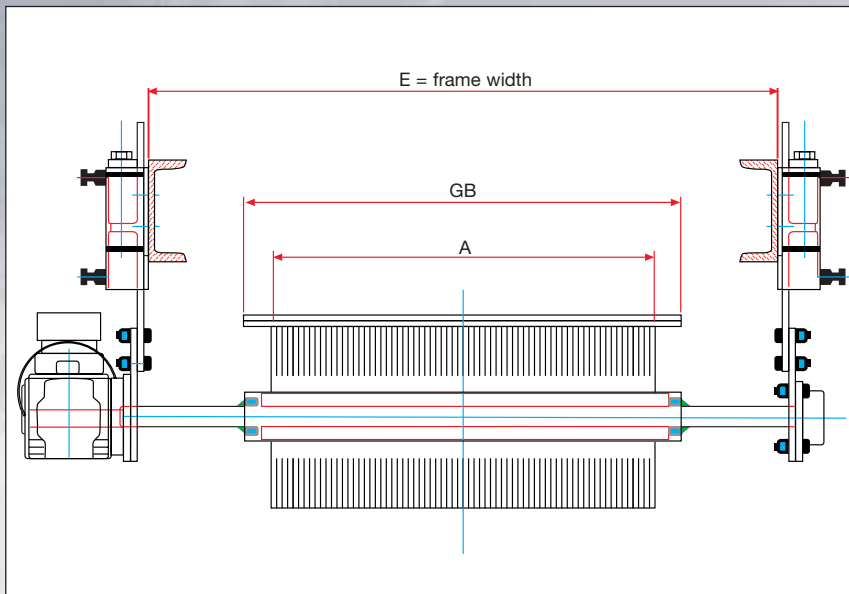

Availability of REMACLEAN SGB:

Ref. No.	Belt width (GB)	A (mm)	E (mm)	Weight (kg)
578 0655	400	300	700	81
578 0662	500	400	800	82
578 0679	600/650	550	950	83
578 0686	750/800	700	1,150	85
578 0693	900	800	1,250	86
578 0703	1,000/1,050	950	1,350	87
578 0796	1,200	1,100	1,600	90
578 0803	1,300/1,400	1,300	1,800	92

TIP
TOP Industrie

REMA TIP TOP/North America Inc
Industrial Division

1500 Industrial Blvd. Madison, GA 30650

Toll Free: 800.334.REMA (7362) • Phone: 706.752.4000 • Fax: 706.752.4015

www.rematiptop.com

ONE BRAND – ONE SOURCE – ONE SYSTEM