

REMACLEAN TMB

Drum motor brush

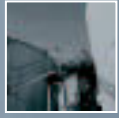

> > > The tailor-made conveyor belt cleaning system

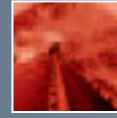
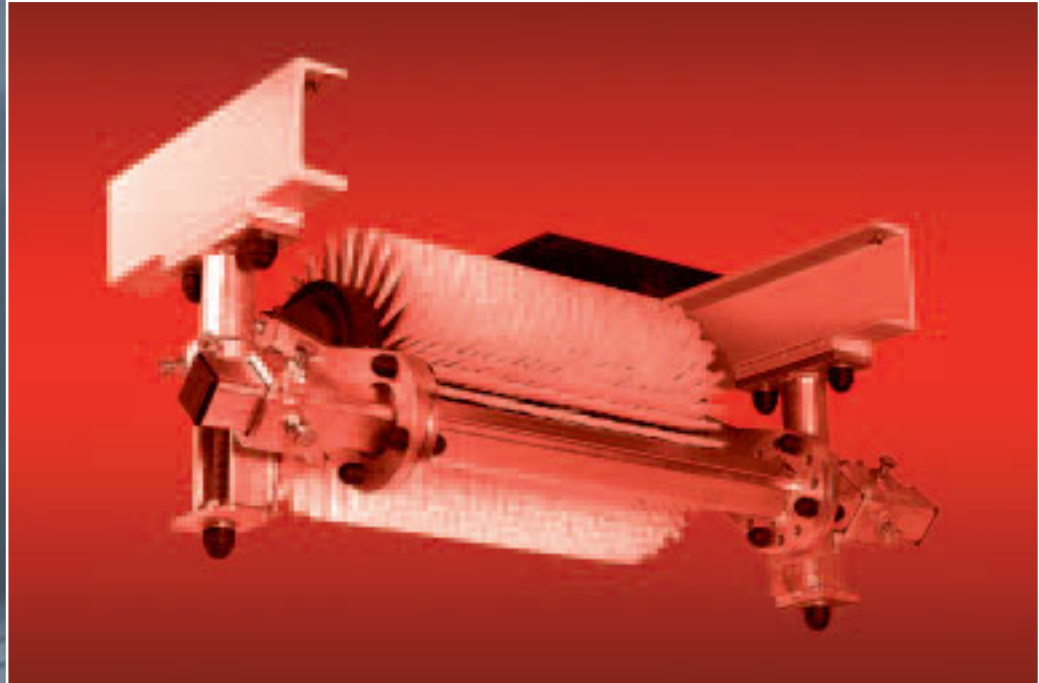

The *REMACLEAN TMB* ensures highly efficient belt cleaning; it provides distinct advantages:

- “Belt friendly” cleaning
- Quick and easy fine adjustment through spindle system
- Various kinds of bristles tailored to solve specific belt cleaning problems
- Suitable for shuttle belt conveyors as the brush is integrated into the electronic control system of the conveyor
- Compact construction thanks to the use of a drum motor
- No laterally protruding parts
- Optimum positioning in the conveyor structure utilizing swivelling mechanism



TIP TOP Industrie

One Name – One Source – One System

We advise. We deliver. We install. We provide customer care.

REMACLEAN TMB

Drum motor brush

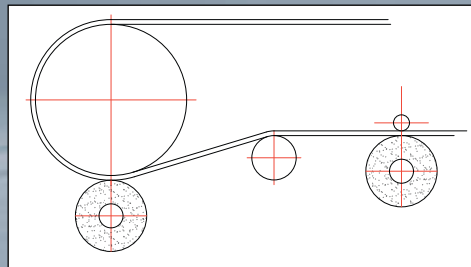
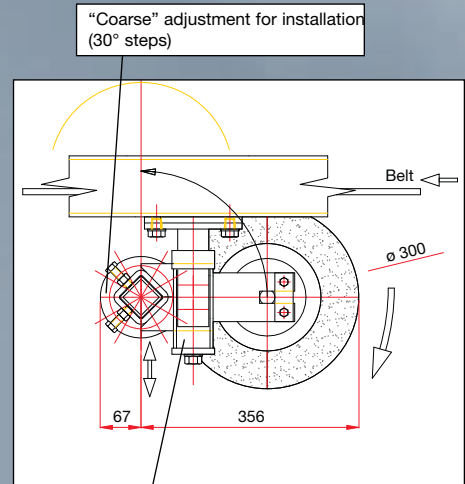
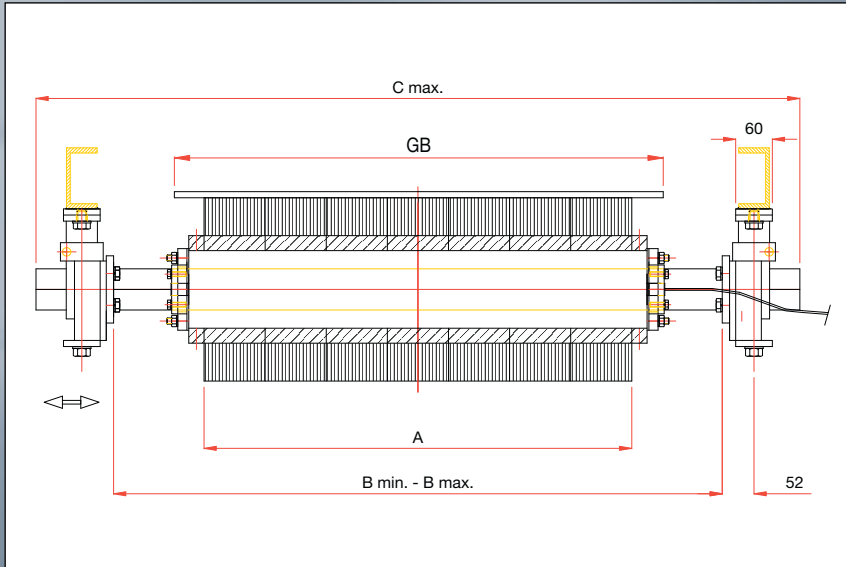

>>> Availability of REMACLEAN TMB:

Ref. No.	Belt width (GB)	A	B min.	B max.	C max.	Weight (kg)
578 0590	400	300	472	1230	1400	71
578 0600	500	400	572	1330	1500	75
578 4802	600/650	500	672	1480	1650	79
578 0617	750/800	700	872	1630	1800	92
578 0624	900	800	972	1730	1900	96
578 0631	1000/1050	900	1072	1880	2050	100
578 0648	1200	1100	1272	2030	2200	119

TIP
TOP Industrie

REMA TIP TOP/North America Inc
Industrial Division

1500 Industrial Blvd. Madison, GA 30650

Toll Free: 800.334.REMA (7362) • Phone: 706.752.4000 • Fax: 706.752.4015

www.rematiptop.com

ONE BRAND – ONE SOURCE – ONE SYSTEM