

SE-Unimont 8-20"

Pos.	Ref.No.	Description
01	5198883 WH 8300	Machine body 8-15"
02	5198883 WH 8213	Lift guide
03	5198883 WH 8214	Trapezoid spindle TR 32 x 3
04	5198883 WH 8215	Fixing flange
05	5198883 WH 8216	Geared motor with brake S0,2 A DA 80 B complete
06	5198883 WH 8217	Flat bar for strap
07	5198883 WH 8218	Cover plate for visual check
08	5198883 WH 8202	Cover plate SE 8-20"
09	5198883 WH 8864	Tyre lever (1 piece)
10	5198883 WH 8305	Set of steps for platform 8-20"
11	5198883 WH 8306	Flat bar 60/10, long
12	5198883 WH 8307	Flat bar 60/10, short
13	5198883 WH 8219	Control unit
14 *	5198883 WH 8220	Press button
15	5198883 WH 8018	Support for platform left hand side with spacer
16	5198883 WH 8019	Support for platform right hand side with spacer
17	5198883 WH 8221	Angular contact ball bearing 100-3205A-2RS1TN9
18	5198883 WH 8222	Feather 6 x 6 x 80 – DIN 6885 A
19	5198883 WH 8701	Spacer 60t
20	5198883 WH 8702	Centring gudgeon length 110 mm
21	5198883 WH 8708	Centring gudgeon length 265 mm
22	5198883 WH 8710	Centring gudgeon length 315 mm
23	5198883 WH 8033	Centring gudgeon length 415 mm
24 *	5198883 WH 8223	limit switch
25 *	5198883 WH 8224	Strap
26	5198883 WH 8225	Lift guide unit
27 *	5198883 WH 8226	Roller Ø35
28	5198883 WH 8227	Roller axle
29 *	5198883 WH 8228	Trapezoid nut TR 32 x 12
30	5198883 WH 8229	Connecting unit
31	5198883 WH 8230	Fixing plate for lift fork
32	5198883 WH 8243	Lift fork
33	5198883 WH 8232	Spacer sleeve Ø22 x 4,5 length 25 mm
35	5198883 WH 6139	Safety latch
36	5198883 WH 6169	Rim ring holder
37	5198883 WH 6170	Tool holder
38A	5198883 WH 8171	Hydraulic unit MP54 – 200 bar - standard model #
38B	5198883 WH 6249	Hydraulic unit MP44 – 200 bar – fast gear model#
38C	5198883 WH 8172	Hydraulic unit MP54 – 315 bar – standard model #
39D	5198883 WH 8173	Hydraulic unit MP54 – 315 bar – fast gear model #
39A	5198883 WH 8798	Spool valve block SG1G-P – 200 bar – standard gear model #
39B	5198883 WH 8712	Spool valve block SKS341-3 – 200 bar – fast gear model #

The parts marked with an asterisk *) are wear parts, for which no liability based on any legal regulations whatsoever can be accepted

39C	5198883 WH 8175	Spool valve block SG1G-P – 315 bar – standard gear model #
39D	5198883 WH 8176	Spool valve block SKS341-3 – 315 bar – fast gear model # (# always specify V + Hz)
40A	5198883 WH 3794	EO-screw link EVT 12 PLR
40B	5198883 WH 3738	EO-screw link EVL 15 PLR ½"
41	5198883 WH 3730	EO-screw link GE 15 PLR ½"
41A	5198883 WH 3796	EO-screw link GE 12 PSR ¼"
41B	5198883 WH 3795	EO-screw link GE 12 PSR
42	5198883 WH 3744	EO-screw link RI 1" x ½"
43	5198883 WH 3747	EO-screw link MAV-EV 12 PLR
44	5198883 WH 3739	EO-screw link KOR 15/12 PL
45	5198883 WH 3743	Sealing ring ¼"
46	5198883 WH 8174	Mounting plate for spool valve block standard model
47B	5198883 WH 3750	EO-screw link GE 15 PLM 18 x 1,5
48	5198883 WH 8794	High pressure hose 2STT DN 10 x 900–BEL90°/BEL90°
49	5198883 WH 8796	High pressure hose 2STT DN 10 x 2300 – BEL/BEL90°
50	5198883 WH 3751	EO-screw link WE 15 PLM 18 x 1,5
51	5198883 WH 8793	High pressure hose 2STT DN 10 x 900 – BEL/BEL90°
52	5198883 WH 8795	High pressure hose 2STT DN 10 x 1800 – BEL/BEL
53	5198883 WH 6255	Manometer Ø62 – 400 bar
54	5198883 WH 8713	High pressure hose DN 12 x 750 – BEL/BEL 90°
55	5198883 WH 8714	High pressure hose DN 12 x 1800 – BEL/BEL 90°
56	5198883 WH 8715	High pressure hose DN 12 x 2300 – BEL/BEL 90°
57 *	5198883 WH 8233	Plate for lift left hand side
58 *	5198883 WH 8234	Plate for lift right hand side
59	5198883 WH 8251	Shaft 8-20"
60 *	5198883 WH 8236	Dry bearing 3040 with bore
61 *	5198883 WH 8237	Dry bearing 3040 without bore
62 *	5198883 WH 4144	Cross handle M 10 x 25
63	5198883 WH 6121	Rubber pad – M 10 outside - Ø50 x 42
64	5198883 WH 8250	Mounting paste holder
65	5198883 WH 3553	Countersunk screw M 8 x 30 – DIN 7991

84	5198883 WH 6154	Rubber pad – 2 x M8 inside - Ø30 x 20
85	5198883 WH 8792	Broad chisel
86	5198883 WH 8238	Electrical mounting plate
87	5198883 WH 8239	Contacteur DIL 00 M
88	5198883 WH 8240	Motor protection switch PKZM 0-10 (for lift)
89	5198883 WH 8241	Motor protection switch PKZM 0-2,5 (for aggregate)
90	5198883 WH 8089	Spacer sleeve Ø25 x 4,5 length 16 mm
91A	5198883 WH 8799	Spare limit switch for standard gear model
91B	5198883 WH 8074	Spare limit switch for fast gear model
92A	5198883 WH 8179	Bracket for standard gear model
92B	5198883 WH 6174	Bracket for fast gear model
93	5198883 WH 6144	Short instructions for SE-UNIMONT

94	5198883 WH 6145	Plexiglass shield
95	5198883 WH 6146	Cover plate
107	5198883 WH 2202	Hexagon cap screw M 10 x 30 – DIN 933
108	5198883 WH 2452	Flat nut M 10 – DIN 936
109	5198883 WH 1888	Setscrew M 6 x 16 – DIN 916
110	5198883 WH 1889	Setscrew M 5 x 6 – DIN 916
111	5198883 WH 1827	Setscrew M 10 x 40 – DIN 914
112	5198883 WH 3561	Countersunk screw M 10 x 40 – DIN 7991
113	5198883 WH 2220	Hexagon cap screw M 16 x 50 – DIN 933
114	5198883 WH 2019	Hexagon cap screw M 14 x 140 – DIN 931
115	5198883 WH 2221	Hexagon cap screw M 10 x 20 – DIN 933
116	5198883 WH 2203	Hexagon cap screw M 8 x 20 – DIN 933
117	5198883 WH 1631	Saucer head screw M 10 x 30 – DIN 603
118	5198883 WH 2204	Hexagon cap screw M 8 x 30 – DIN 933
119	5198883 WH 2208	Hexagon cap screw M 8 x 12 – DIN 933
120	5198883 WH 1769	Fillister head screw M 8 x 20 – DIN 912
121	5198883 WH 2244	Hexagon cap screw M 24 x 90 – DIN 933
122	5198883 WH 1483	Washer R 26 – DIN 440
123	5198883 WH 1211	Washer Ø17 – DIN 125
124	5198883 WH 1480	Washer R 18 – DIN 440
125 *	5198883 WH 8180	Thread bar M 12 x 360 mm
126	5198883 WH 2009	Hexagon cap screw M 8 x 50 – DIN 931
127	5198883 WH 1627	Saucer head screw M 10 x 100 – DIN 603
128	5198883 WH 1626	Saucer head screw M 6 x 50 – DIN 603
129	5198883 WH 1759	Fillister head screw M 16 x 40 – DIN 912 – quality 12.9
130	5198883 WH 1797	Fillister head screw M 5 x 10 – DIN 912
131	5198883 WH 3559	Countersunk screw M 5 x 10 – DIN 7991
132 *	5198883 WH 5431	Eye bolt M 10 x 20
133	5198883 WH 2677	Safety nut M 10 – DIN 985
134	5198883 WH 2678	Safety nut M 8 – DIN 985
135	5198883 WH 2679	Safety nut M 12 – DIN 985
136	5198883 WH 2680	Safety nut M 14 – DIN 985
137	5198883 WH 2408	Hexagon nut M 6 – DIN 934
138	5198883 WH 2403	Hexagon nut M 24 – DIN 934
139	5198883 WH 1402	Wing nut M 8 – DIN 315
140	5198883 WH 1204	Washer Ø8,4 – DIN 125
141	5198883 WH 1203	Washer Ø 10,5 – DIN 125
142	5198883 WH 8182	Bracket for platform right hand side
143	5198883 WH 8183	Bracket for platform left hand side
144	5198883 WH 8187	Support for platform left hand side
145	5198883 WH 2219	Hexagon cap screw M 6 x 12 – DIN 933
146	5198883 WH 8188	Support for platform right hand side
147	5198883 WH 8780	Flat butt strap 40/8
148	5198883 WH 8194	Spacer sleeve length 32 mm
148A	5198883 WH 8242	Spacer sleeve length 22 mm

149	5198883 WH 8189	Connecting bracket left hand side
150	5198883 WH 8190	Connecting bracket right hand side
151	5198883 WH 8191	Set of steps for platform – for „Servicemobil“
152	5198883 WH 2221	Hexagon cap screw M 10 x 20 – DIN 933
153	5198883 WH 1203	Washer Ø 10,5 – DIN 125
154 *	5198883 WH 8093	Scraper DA 17 – 1000 – N90
155 *	5198883 WH 8782	Stepseal with O-ring S55013-1000-346-8307
156 *	5198883 WH 3952	Compact seal SK 200-1
157 *	5198883 WH 3958	O-ring no. 367-8307
158	5198883 WH 8097	Top plate of piston rod - Ø195 x 40 mm
159	5198883 WH 8786	Cover plate Ø100 x 6 mm
160	5198883 WH 8787	Guide head (without seals)
161	5198883 WH 3960	3-piece closing ring Da211 x d10
162 *	5198883 WH 8106	Piston rod with piston – stroke 500 mm
163	5198883 WH 8108	Cylinder with bottom plate – stroke 500 mm
164	5198883 WH 8791	Hydraulic cylinder complete DS 200/500

SE Unimont 8-20"

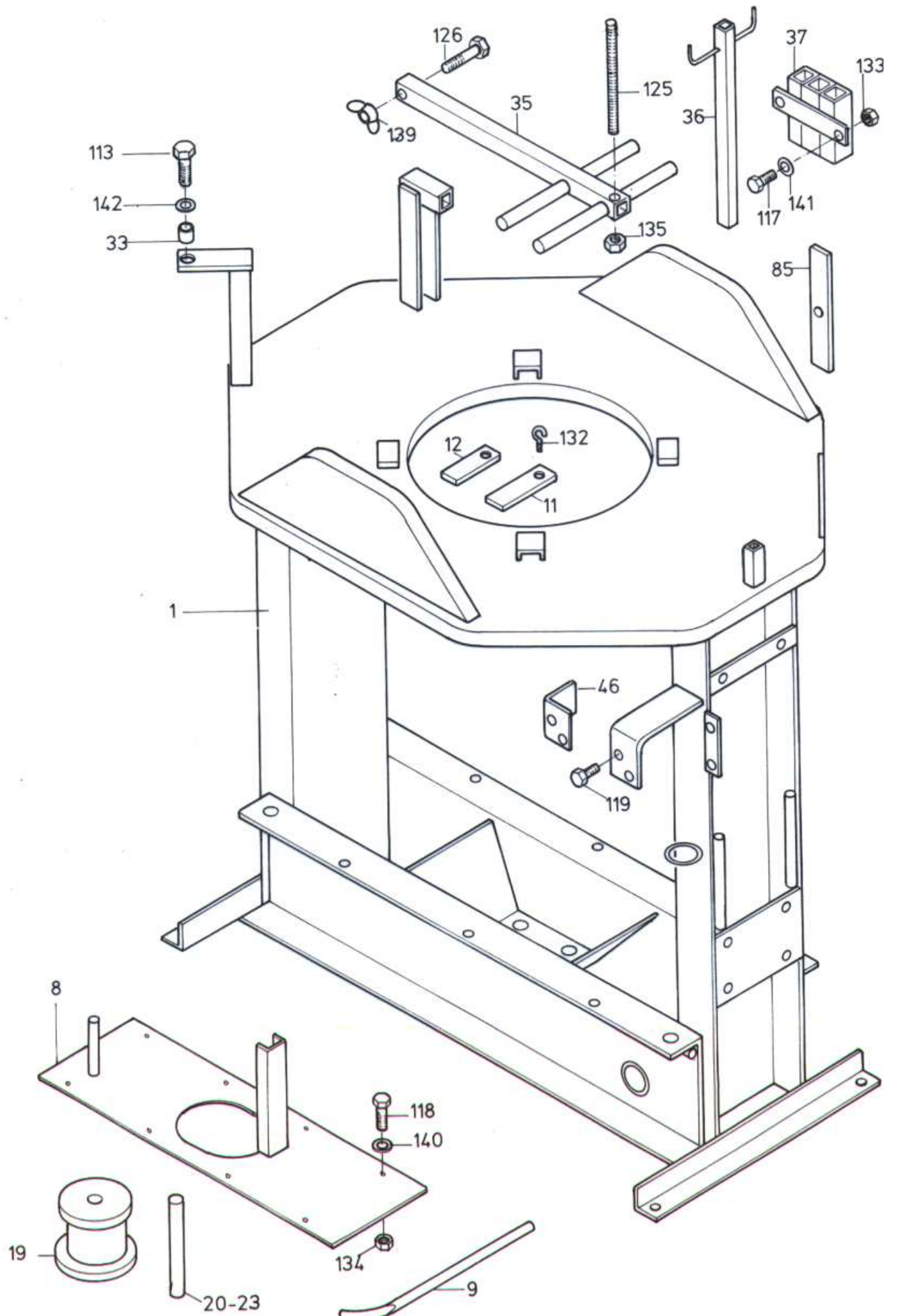

Fast gear model

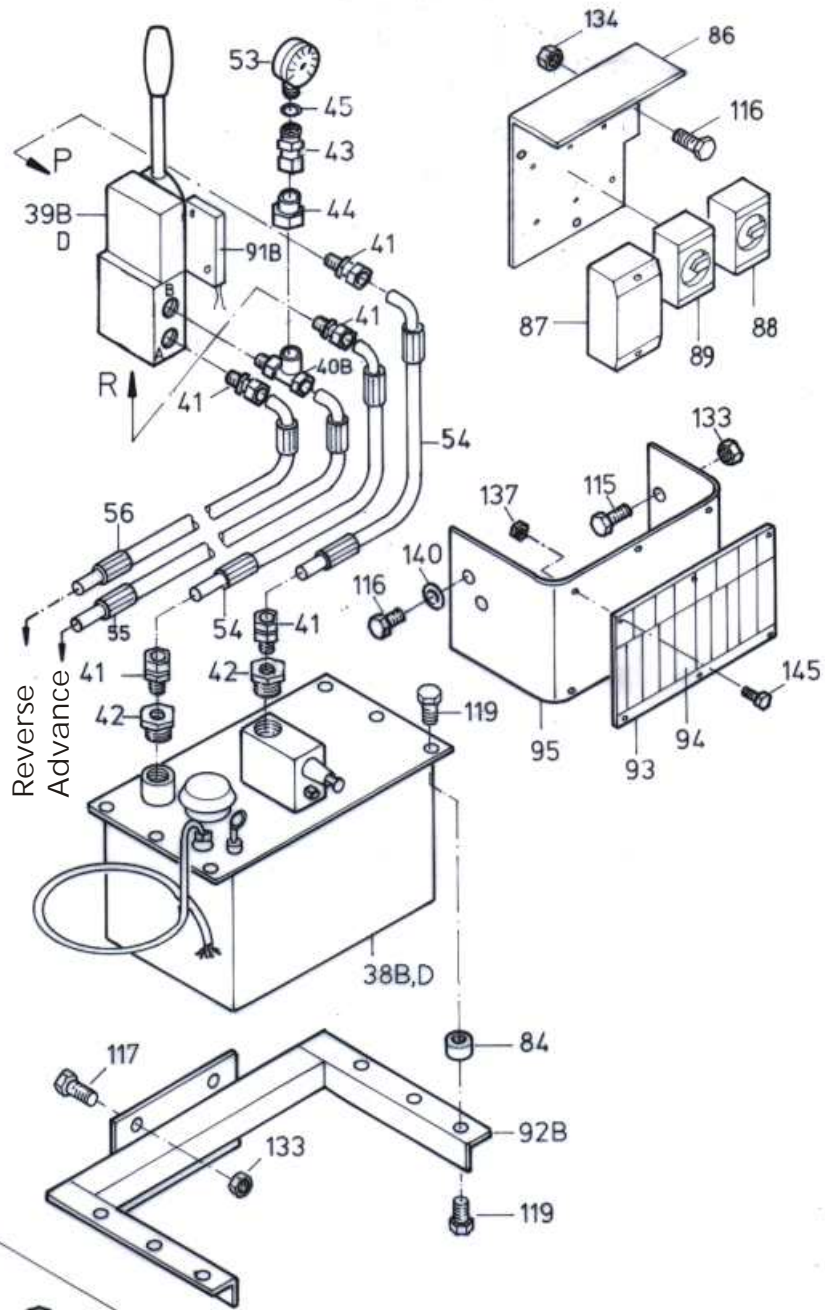

Workshop

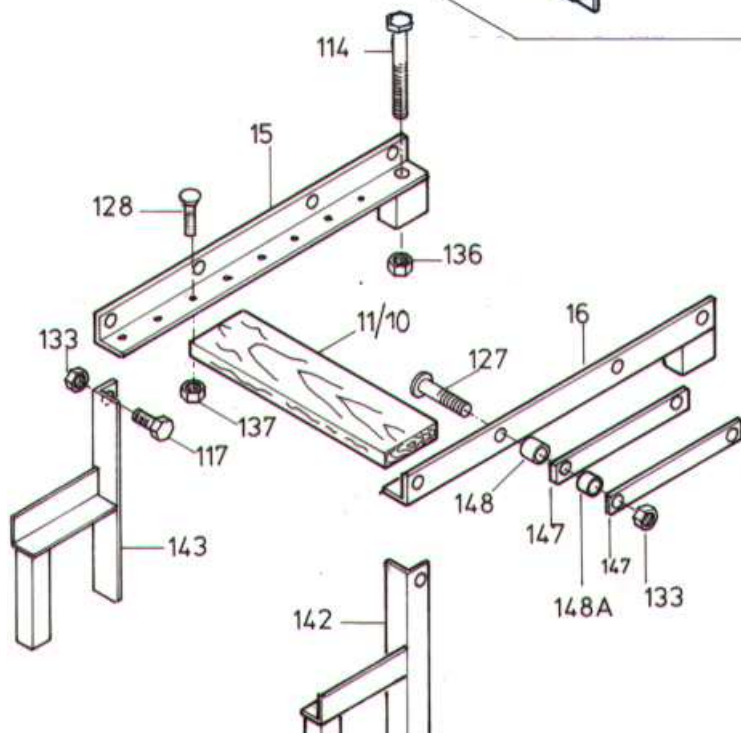

Mobil service unit "Servicemobil"

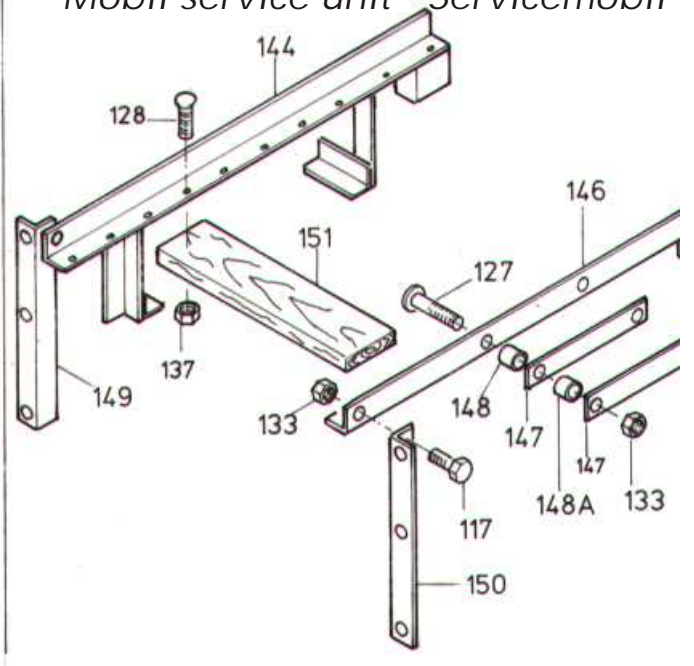

Standard model

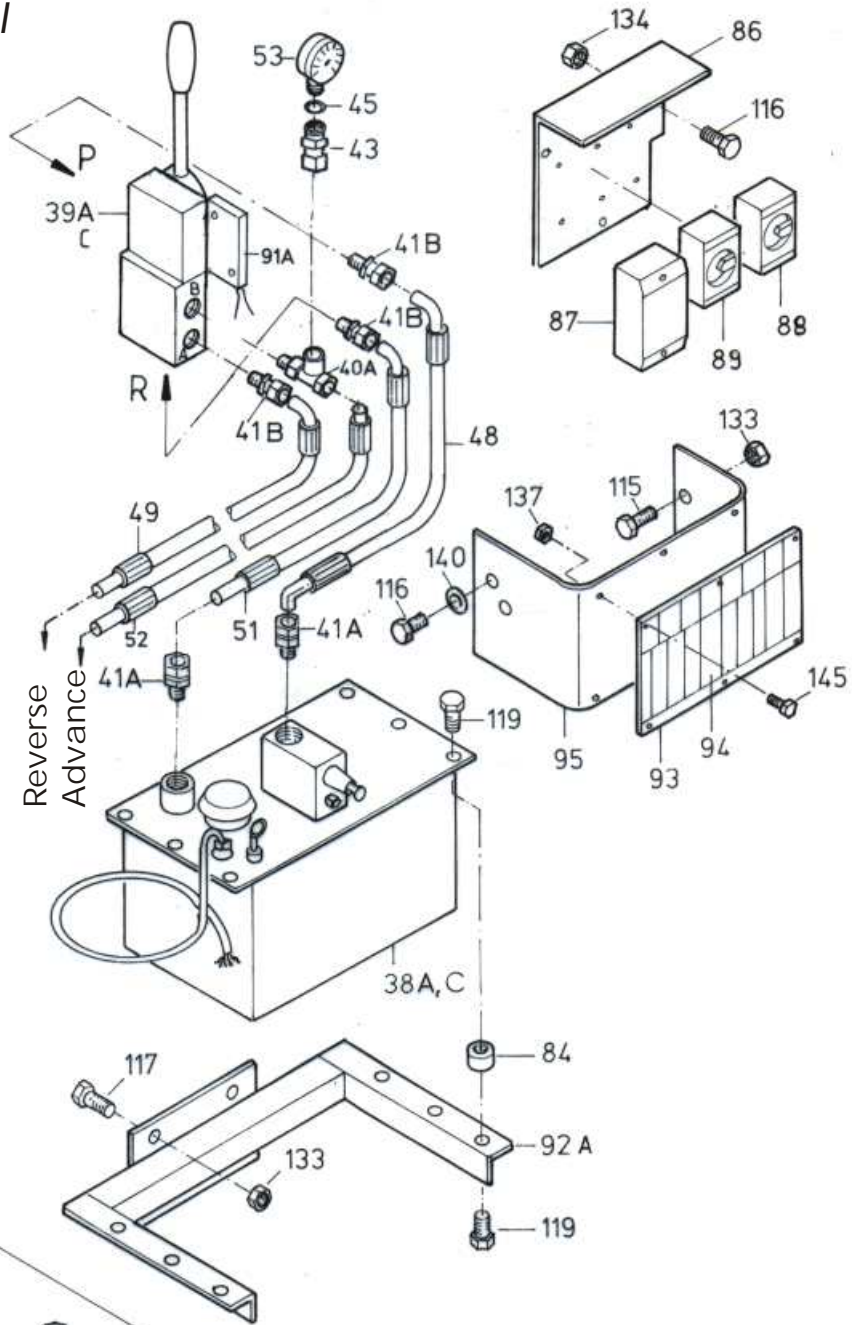

Workshop

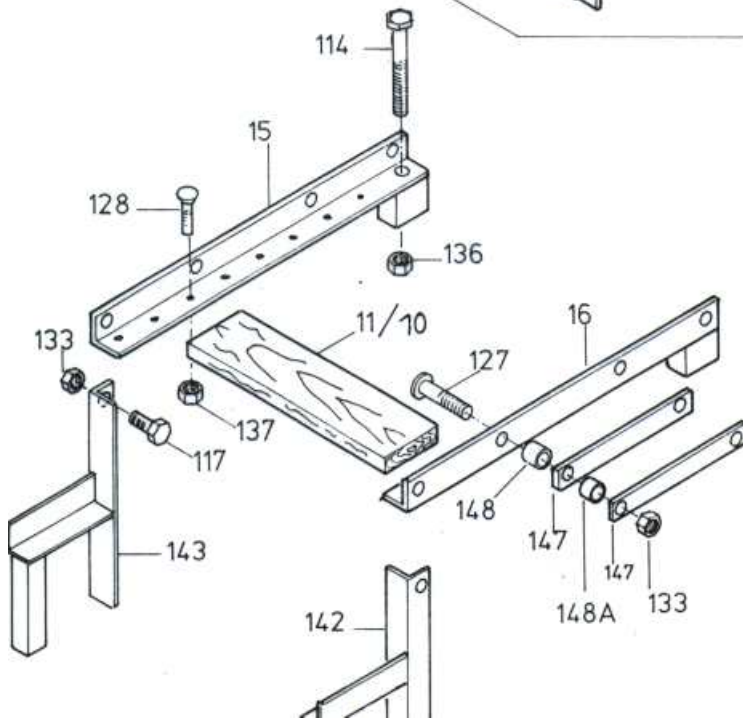

Mobil service unit "Servicemobil"

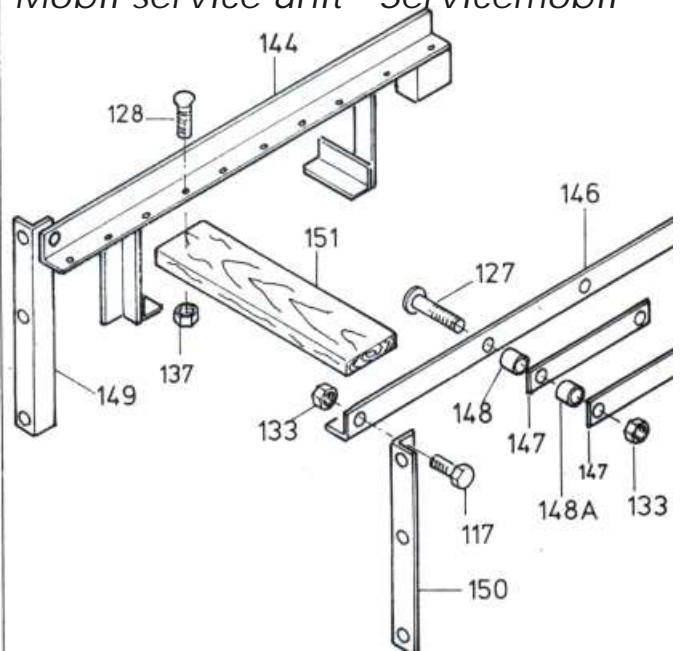

Lift SE 8-15" / 8-20"

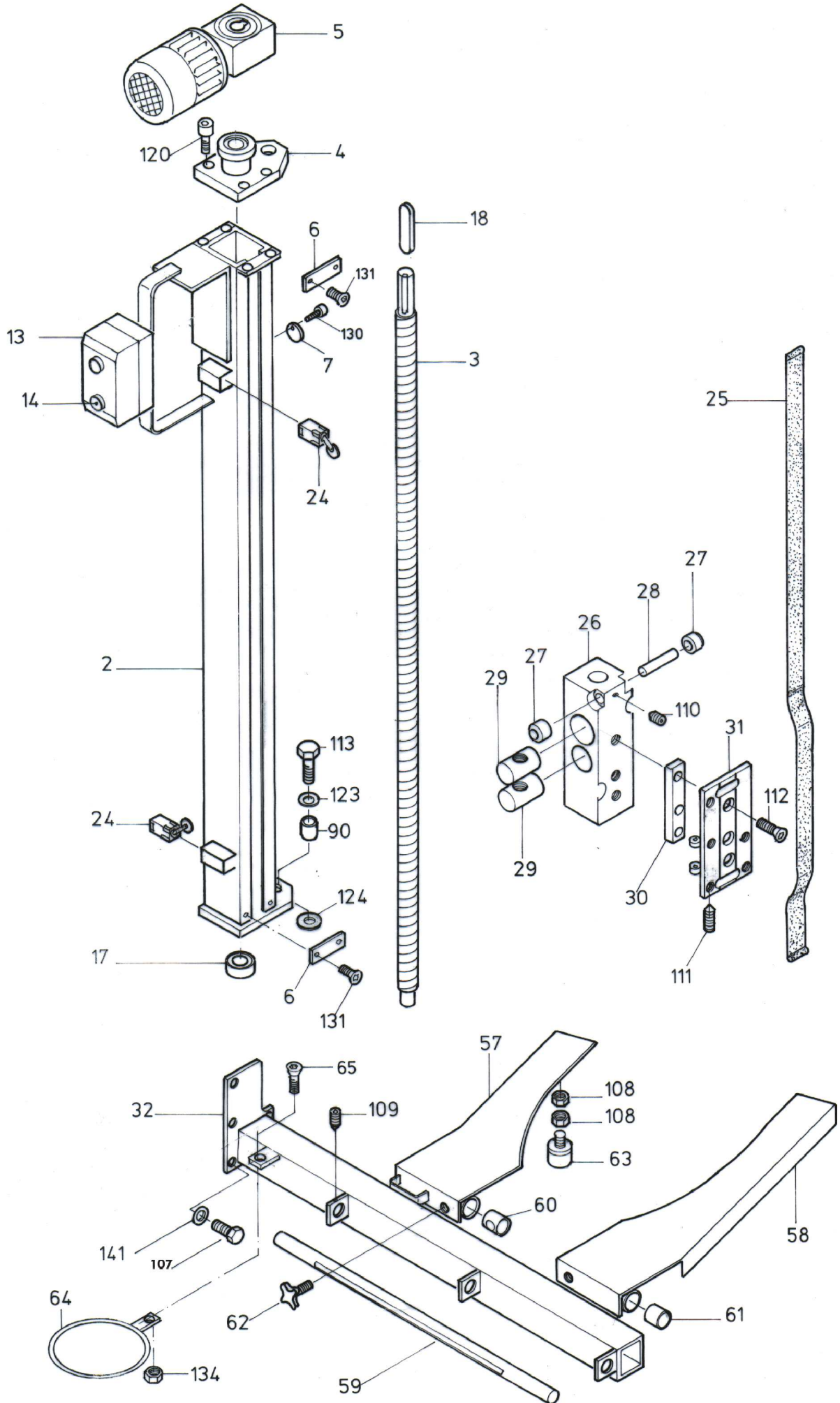

Hydraulic cylinder type DS 200/500

